

PRO-FIND

Precision Pinpointing

Manuale d'uso



PERFORMANCE // IS EVERYTHING



 *Detector Center*

Detector Center Distributore Ufficiale e Centro Assistenza Minelab per l'Italia
Via del Lavoro, 4 - 48015 Cervia (RA) tel. 0544.1888019 / 0544.1888009
www.minelab.it - info@minelab.it



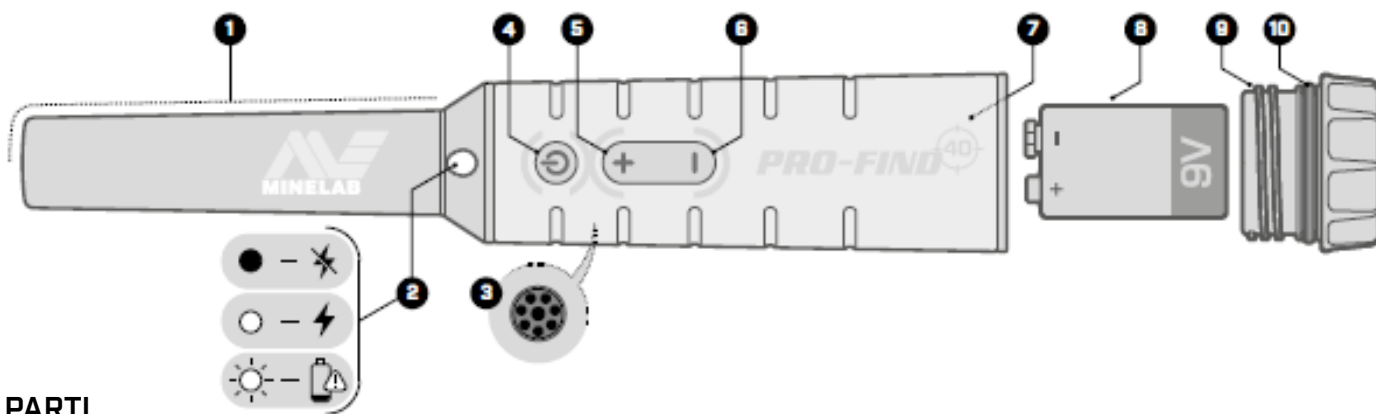

PARTI

- | | |
|---------------------------|------------------------|
| 1. Area di rilevazione | 6. Pulsante meno [-]. |
| 2. Torcia LED | 7. Vano batteria |
| 3. Altoparlante | 8. Batteria PP3 da 9 V |
| 4. Pulsante di accensione | 9. Tappo batteria |
| 5. Pulsante più [+]. | 10. O-ring |

MANUTENZIONE

- Mantenere pulite le filettature delle viti del coperchio della batteria e l'O-ring.
- Lubrificare periodicamente l'O-ring con grasso al silicone.

ACCENDERE

0.5 s

SPEGNERE

> 0.5 s

ATTIVARE L'AUDIO

DISATTIVARE L'AUDIO

ATTIVARE L'AUDIO FERROSO

3 s

ATTIVARE L'AUDIO FERROSO

3 s

REGOLARE LA SENSIBILITÀ

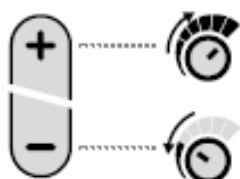

SEGNALE AUDIO TARGET

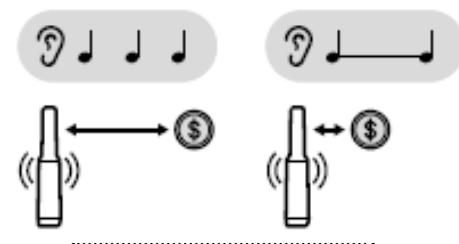

SEGNALE AUDIO FERROSO

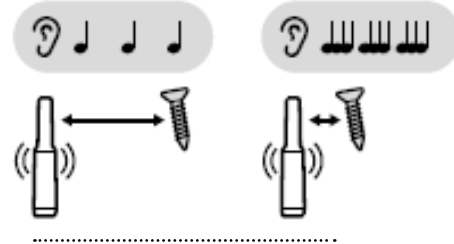

RE-TUNE RAPIDO

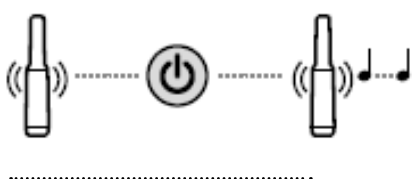

ALLARME INATTIVO

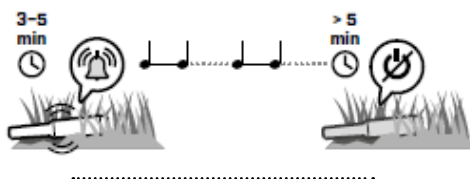

RITORNO ALLE IMPOSTAZIONI DI FABBRICA

